

# PM Series

## Decorative, Vetro Pendant LED

### Suspension Kits

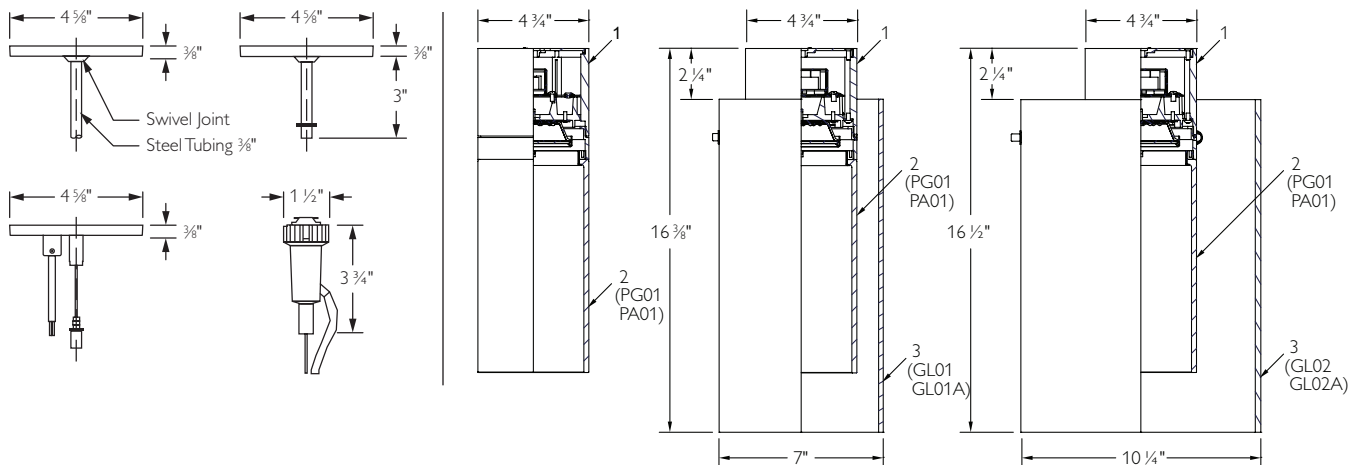

### Power Heads:

Cat. No.	Lamp	Wts	CCT	Volts
PM01L27SA1	LED	10W	27k	120V
PM01L27SA2				277V
PM01L30SA1			30k	120V
PM01L30SA2				277V
PM01L35SA1			35k	120V
PM01L35SA2				277V
PM01L40SA1			40k	120V
PM01L40SA2		277V		
PM02L27SA1		20W	27k	120V
PM02L27SA2				277V
PM02L30SA1			30k	120V
PM02L30SA2				277V
PM02L35SA1			35k	120V
PM02L35SA2				277V
PM02L40SA1	40k		120V	
PM02L40SA2		277V		

### Suspension Kits:

Cat.	Finish	Description
SK01	Satin	Clear Metallic Straight Cord/Cable, 120" Length, (10') w/Canopy
		Clear Metallic Straight Cord/Cable, 300" Length, (25') w/Canopy
ST01	Aluminum	36" Length 3/8" Stem w/Canopy
ST02		60" Length 3/8" Stem w/Canopy
CTC		Close to Ceiling Kit
TM01		Track Mounting Kit

**Note:** Power Head, Primary Glass and Suspension Kit must be ordered to make complete Luminaire. Outer Glass is optional.

### Glass/Acrylic:

Cat.	Description	Compatibility
PG01	Inner Opal Glass	Required for all glass options
PA01	Inner Opal Acrylic	Required for all acrylic options
GL01	7" Outer Clear Glass	Optional for all power heads
GL02	10 1/4" Outer Clear Glass	
GL01A	7" Outer Clear Acrylic	
GL02A	10 1/4" Outer Clear Acrylic	

Job Information	Type:
Job Name:	
Cat. No.:	
Notes:	

# PM Series

## Decorative, Vetro Pendant LED

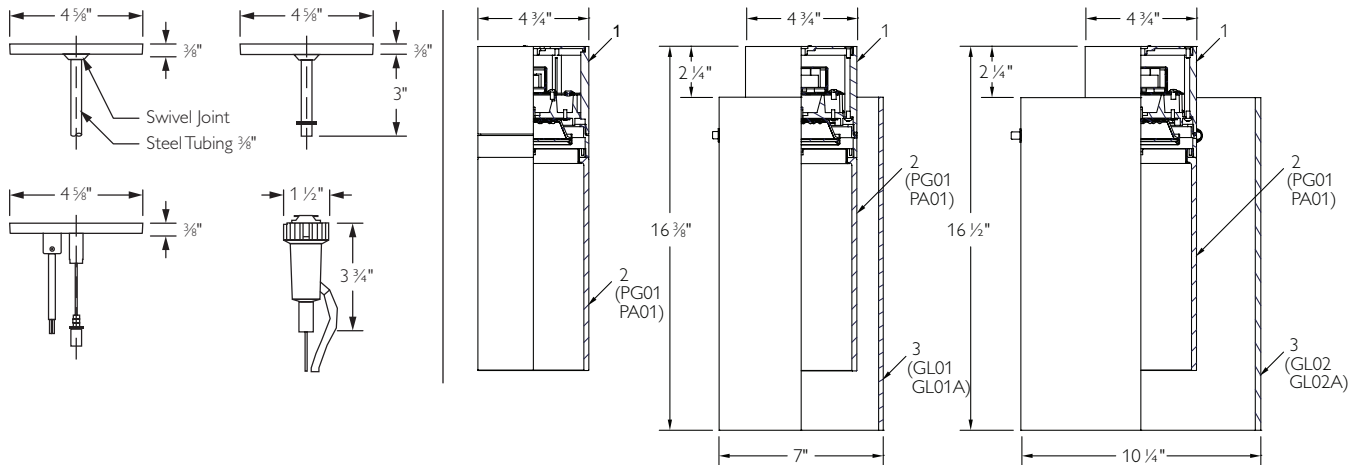

### Features

- 1. Power Head:** Die cast and extruded aluminum components. Brushed and clear lacquer finish.
- 2. Primary Diffuser:** (PG01) Triplex hand blown glass or (PA01) opal acrylic.
- 3. Outer Glass/Acrylic Assembly:** (GL01) A 7" diameter straight section of clear extruded glass with polished edges, (GL02) a 10 1/4" diameter straight section of clear extruded glass with polished edges, (GL01A) a 7" diameter straight section of clear acrylic, or (GL02A) a 10 1/4" diameter straight section of clear acrylic. All outer assemblies come with a die cast aluminum holder ring with stainless steel support pins.
- 4. Optical Mixing Chamber:** Remote phosphor technology provides increased efficiency and color stability. Phosphor lens assembly positioned in front of LED array converts blue light to white and produces a wide even pattern of diffused light without bright spots created by individual LEDs. Uniform phosphor coating provides consistent, stable color with a shift of no more than +/-100K over life. Mixing chamber redirects scattered light back out through the emitting aperture.
- 5. Thermal Management:** Heat sink design maintains junction temperature for consistent, reliable performance and 50,000 hour lifetime at 70% lumen maintenance.

### Electrical

- LED Board:** 10W: Array of 8 high brightness royal blue LEDs.  
20W: Array of 16 high brightness royal blue LEDs.
- Electronic Power Supply:** 120 or 277V, 50/60Hz, encased, overload and short circuit protected, thermal regulation to protect against overheating, sound rating "A", -20° C minimum starting temp, 40° C maximum operating temp.
- Dimming Capability:** See LED-DIM Spec Sheet.

#### 10W:

Input Voltage	Input Frequency	Input Current	LED Drive Current	Input Power	LED Power	THD	Power Factor
120V	50/60Hz	0.074	350mA	9W*	8W	<5%	>0.9
277V	50/60Hz	0.032	350mA	9W*	8W	<10%	>0.8

#### 20W:

Input Voltage	Input Frequency	Input Current	LED Drive Current	Input Power	LED Power	THD	Power Factor
120V	50/60Hz	0.167	350mA	20W*	18W	<5%	>0.9
277V	50/60Hz	0.072	350mA	20W*	18W	<10%	>0.8

\*+/-5%

### Labels

cULus for damp locations.

Job Information	Type:
-----------------	-------

**PHILIPS**  
**LIGHTOLIER**

### PM01L40SA1-PG01

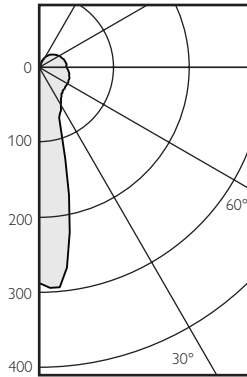

Zonal Lumens and Percentages			
Zone	Lumens	%Lamp	%Fixt
0-30	92	13	19
0-40	122	18	26
0-60	195	28	41
0-90	318	46	66
90-180	161	23	34
0-180	479	69	100

Catalog No:  
PM01L40SA1PG01  
Report No.: 4193FR  
Total Fixture Lumens: 479 lm  
Color Temp: 4000K  
LED Lumens: 690 lm  
Total Luminaire Efficiency: 69.0%  
Input Watts: 10W  
Luminaire Efficacy: 48 lm/w  
CRI: 76

Candela Array		Vertical Angles	
Angle	Mean CP	Angle	Mean CP
0	290	90	34
5	296	95	35
10	225	100	34
15	128	105	33
20	73	110	31
25	65	115	30
30	55	120	28
35	49	125	26
40	46	130	24
45	44	135	22
50	43	140	20
55	43	145	17
60	43	150	15
65	42	155	12
70	41	160	9
75	40	165	3
80	38	170	1
85	36	175	1

#### Coefficients Of Utilization - Zonal Cavity Method

Effective Floor Cavity Reflectance 0.20										
RC	80			70			50			0
RW	70	50	30	70	50	30	50	30	10	0
0	77	77	77	73	73	73	64	64	64	46
1	68	64	60	64	60	57	53	50	48	34
2	61	55	50	57	52	47	46	42	39	27
3	56	48	42	52	45	40	40	36	32	23
4	51	43	37	48	40	35	36	31	28	20
5	47	39	32	44	36	31	32	28	24	17
6	44	35	29	41	33	27	29	25	21	16
7	41	32	26	38	30	25	27	23	19	14
8	38	29	24	36	28	23	25	21	18	13
9	36	27	22	34	26	21	23	19	16	12
10	34	25	20	32	24	19	22	18	15	11

Power head tested using absolute photometry as specified in LM79: IESNA Approved Method for the Electrical and Photometric Measurements of Solid-State Lighting Products. Luminaire with glass tested by relative photometric method.

### PM02L40SA1-PG01

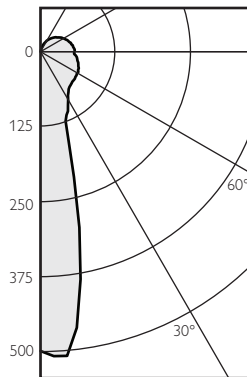

Zonal Lumens and Percentages			
Zone	Lumens	%Lamp	%Fixt
0-30	155	13	19
0-40	206	18	26
0-60	326	28	41
0-90	528	46	67
90-180	262	22	33
0-180	790	68	100

Catalog No: PM02L40SA1-PG01  
Report No.: 4196FR  
Total Fixture Lumens: 790 lm  
Color Temp: 4000K  
LED Lumens: 1155 lm  
Total Luminaire Efficiency: 68.0%  
Input Watts: 20W  
Luminaire Efficacy: 40 lm/w  
CRI: 76

Candela Array		Vertical Angles	
Angle	Mean CP	Angle	Mean CP
0	498	90	56
5	508	95	57
10	384	100	55
15	215	105	53
20	122	110	51
25	108	115	49
30	92	120	46
35	81	125	43
40	75	130	39
45	73	135	36
50	72	140	32
55	71	145	28
60	70	150	24
65	69	155	22
70	67	160	15
75	65	165	10
80	62	170	7
85	59	175	1

#### Coefficients Of Utilization - Zonal Cavity Method

Effective Floor Cavity Reflectance 0.20										
RC	80			70			50			0
RW	70	50	30	70	50	30	50	30	10	0
0	76	76	76	72	72	72	63	63	63	46
1	67	63	60	63	59	56	52	50	48	34
2	61	55	49	57	51	47	45	41	38	27
3	55	48	42	52	45	40	40	35	32	23
4	51	42	36	47	40	35	35	31	27	20
5	47	38	32	44	36	31	32	28	24	17
6	43	35	29	41	33	27	29	25	21	16
7	40	32	26	38	30	25	27	22	19	14
8	38	29	23	36	28	23	25	21	18	13
9	36	27	22	33	26	21	23	19	16	12
10	34	25	20	32	24	19	22	18	15	11

Power head tested using absolute photometry as specified in LM79: IESNA Approved Method for the Electrical and Photometric Measurements of Solid-State Lighting Products. Luminaire with glass tested by relative photometric method.



Philips Lightolier  
e: lol.webmaster@philips.com  
t: (508) 679-8131  
w: www.lightolier.com

PM-LED October 18, 2011

Specifications are subject to change without notice.  
© Koninklijke Philips Electronics N.V., 2011. All rights reserved.

**Job Information** Type: